



NDL INDUSTRIES INC.

The high quality that you require at competitive prices.

Transformer

10011SHCB

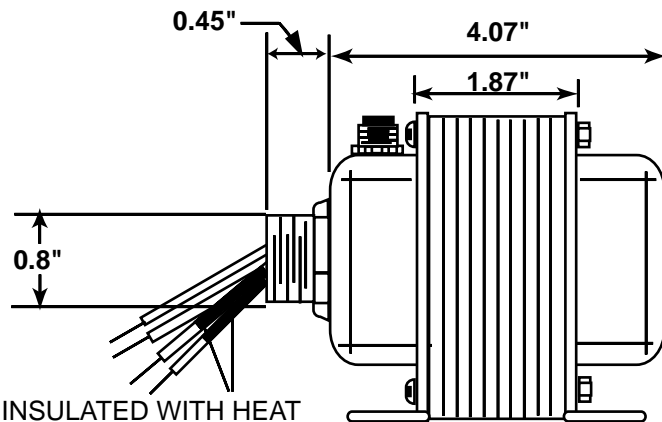
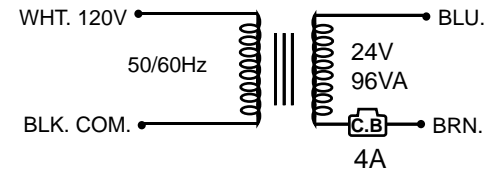
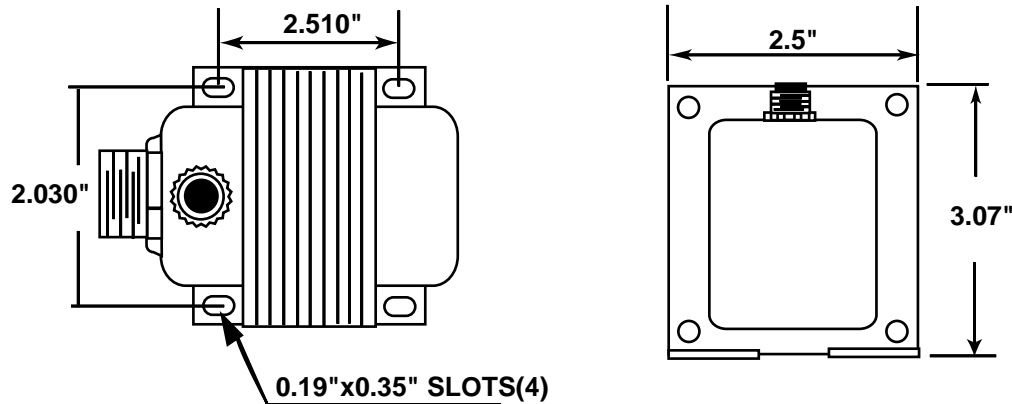

SEC. INSULATED WITH HEAT SHRINKABLE TUBE IN BLACK.
UL1015#18 LENGTH 8" IN COLOR "BLACK", "WHITE", "BLUE" & "BROWN"

Frequency	50/60Hz
Power Rating	96VA
Primary Voltage	120V
Secondary Voltage	24V
Insulation System	Class B

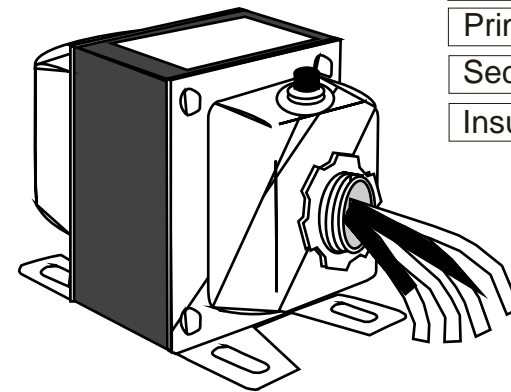

UNIT: inch \pm 0.04

NDL INDUSTRIES INC.

266 S.W. Marine Drive, Vancouver, BC Canada V5X 2R5

Toll Free 1 866 635 6888 Tel. (604) 736 7470 Fax (604) 736 0164

www.ndlinc.com