

NDL
FITTING YOUR NEEDS
Transformer



NDL INDUSTRIES INC.

The high quality that you require at competitive prices.

4011MWSH

Single Hub

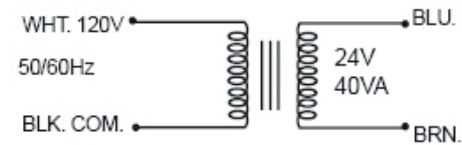
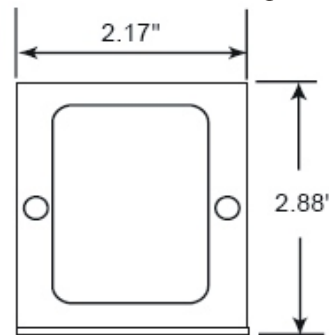
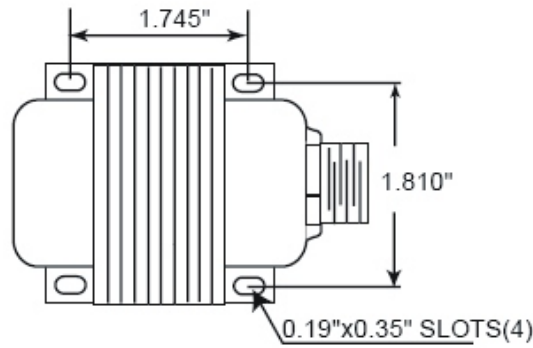

Frequency	50/60HZ
Power Rating	40VA
Primary Voltage	120
Secondary Voltage	24
Insulation System	Class B

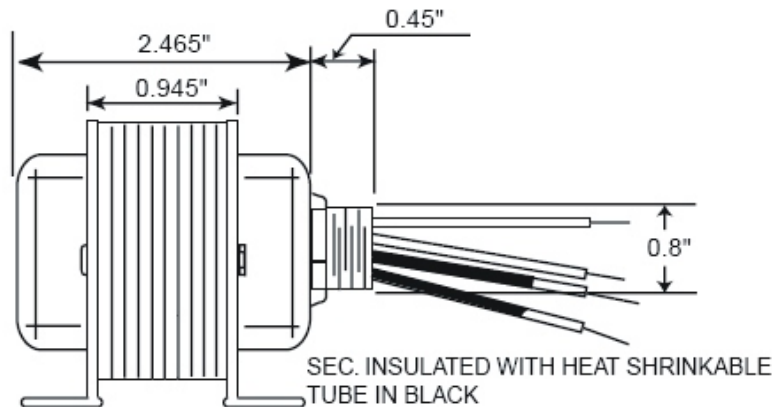

UL1015#18 LENGTH 8" IN COLOR
"BLACK", "WHITE", "BLUE" & "BROWN"

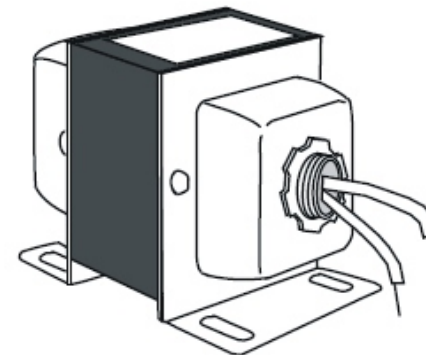

UNIT: inch ±0.04

NDL INDUSTRIES INC.

266 S.W. Marine Drive, Vancouver, BC Canada V5X 2R5
Toll Free 1 866 635 6888 Tel. (604) 736 7470 Fax (604) 736 0164

www.ndlinc.com