



FITTING YOUR NEEDS

Transformer



NDL INDUSTRIES INC.

The high quality that you require at competitive prices.

40110F
Open Frame

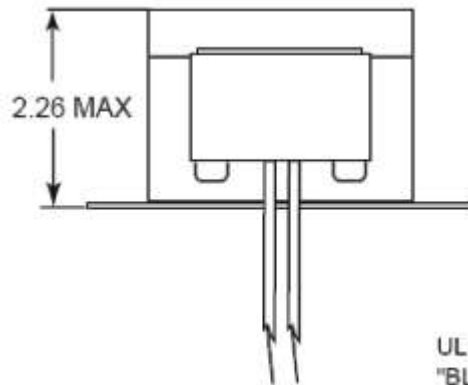
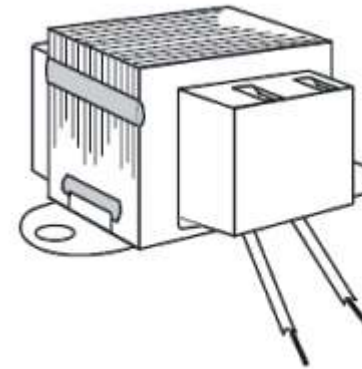
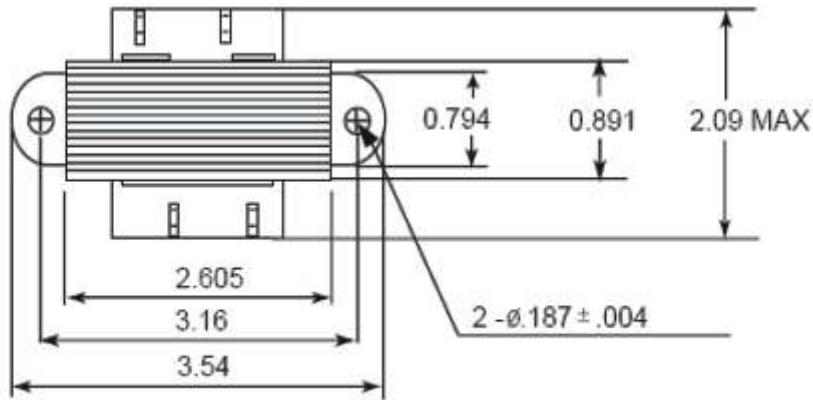

UL1015#18 LENGTH 8" IN COLOR "BLUE" & "GREEN"

UL1015#18 LENGTH 8" IN COLOR "BLACK" & "WHITE"

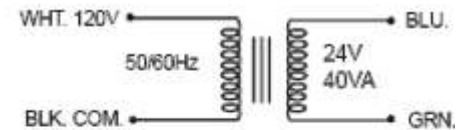

Frequency	50/60HZ
Power Rating	40VA
Primary Voltage	120
Secondary Voltage	24
Insulation System	Class B

UNIT: inch ± 0.04

NDL INDUSTRIES INC.

266 S.W. Marine Drive, Vancouver, BC Canada V5X 2R5

Toll Free 1 866 635 6888 NDL Tel. (604) 736 7470 NDL Fax (604) 736 0164

www.ndlinc.com