



NDL
FITTING YOUR NEEDS
Transformer



402770F
Open Frame

NDL INDUSTRIES INC.
The high quality that you require at competitive prices.

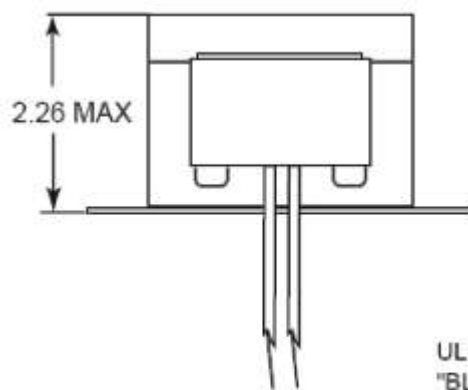
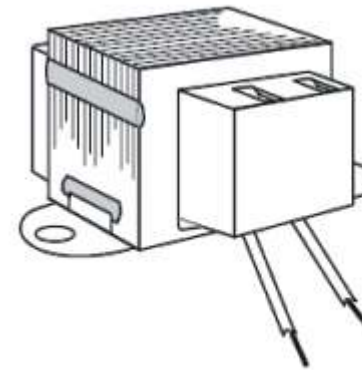
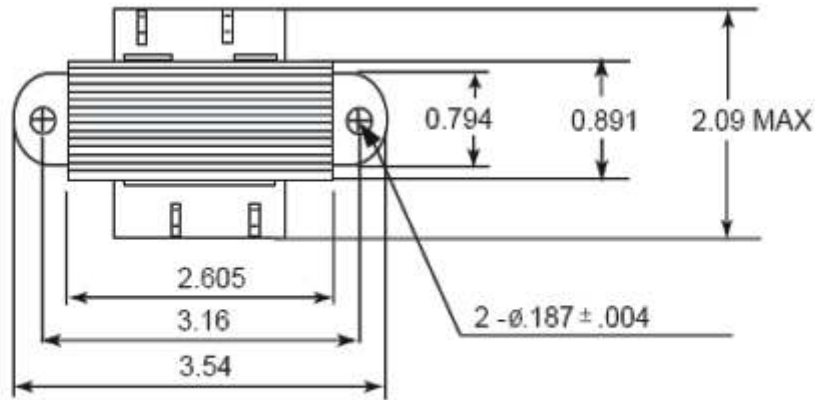

UL1015#18 LENGTH 8" IN COLOR
"BLUE" & "GREEN"

UL1015#18 LENGTH 8" IN COLOR
"BLACK" & "WHITE"

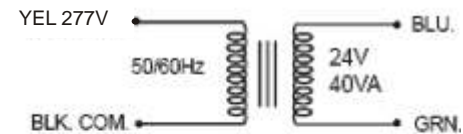

Frequency	50/60HZ
Power Rating	40VA
Primary Voltage	277V
Secondary Voltage	24
Insulation System	Class B

UNIT: inch ± 0.04