



NDL INDUSTRIES INC.

The high quality that you require at competitive prices.

Transformer

5011SHMWCB

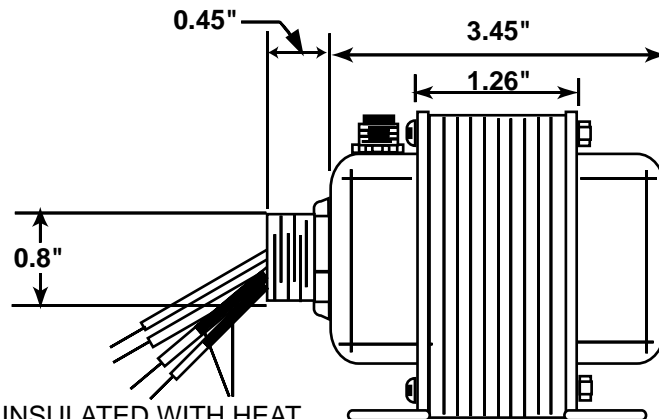
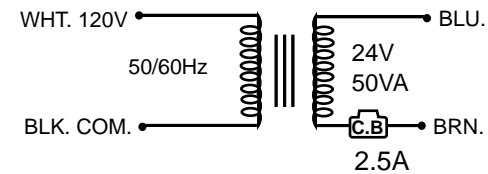
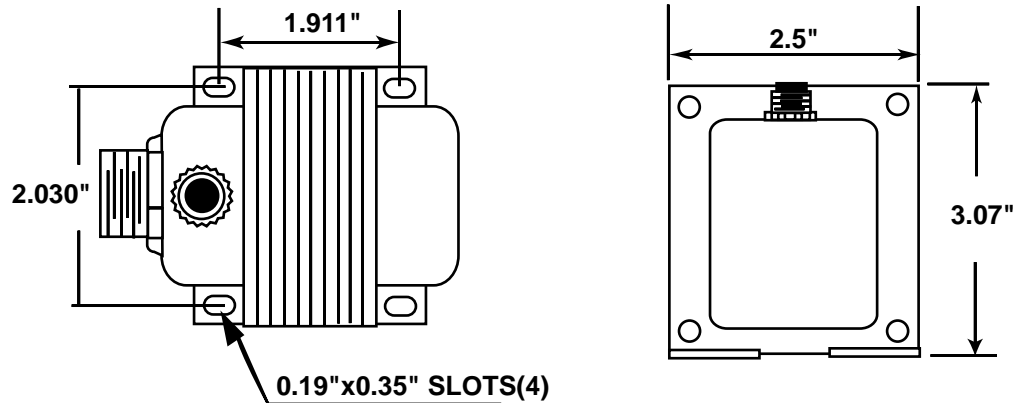

SEC. INSULATED WITH HEAT SHRINKABLE TUBE IN BLACK.
 UL1015#18 LENGTH 8" IN COLOR
 "BLACK", "WHITE", "BLUE" & "BROWN"

Frequency	50/60Hz
Power Rating	50VA
Primary Voltage	120
Secondary Voltage	24V
Insulation System	Class B

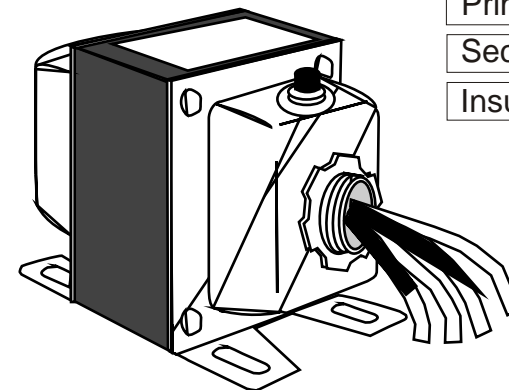

UNIT: inch \pm 0.04